

Performa Nova™

Fully coated CTMP board with uncoated reverse, FiberLight Tec™

Performa Nova is a pigment coated GC2 board with a three-layer fiber construction and CTMP (chemi-thermo-mechanical pulp) in the middle layer, produced with patented FiberLight Tec™ production technology. It is multiple pigment coated on the top side and has an uncoated reverse side. Performa Nova has no OBA added and is also available hard-sized (HS).

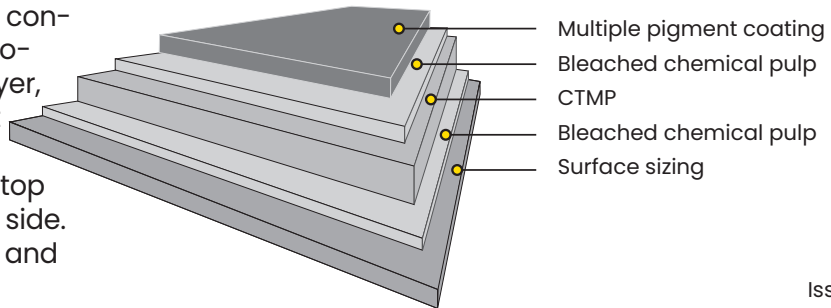

Issued: 05/2026
Replaces: 02/2026

Technical specification

Property	Unit	Tolerance										Standard
Grammage	g/m ²	±4%	200	225	245	260	270	285	300	315		ISO 536
Thickness	µm	±5%	305	356	406	432	457	483	508	533		ISO 534
Caliper	pts		12.0	14.0	16.0	17.0	18.0	19.0	20.0	21.0		
Bending resistance L&W 15° MD	mN	-15%	187	282	362	429	503	577	658	750		ISO 2493
Bending resistance L&W 15° CD	mN	-15%	85	128	165	195	230	262	299	341		ISO 2493
Bending moment Taber 15° MD	mNm	-15%	9.0	13.6	17.5	20.7	24.3	27.9	31.8	36.2		
Bending moment Taber 15° CD	mNm	-15%	4.1	6.2	8.0	9.4	11.1	12.7	14.4	16.5		
ISO Brightness C/2°, Top	%	min. 80	84	84	84	84	84	84	84	84		ISO 2470-1
Surface Smoothness PPS10, Top	µm	max. 1.5	1.0	1.0	1.0	1.0	1.0	1.0	1.0	1.0		ISO 8791-4
Gloss 75°	%		45	45	45	45	45	45	45	45		ISO 8254-1
Scott Bond	J/m ²	min. 110	150	150	150	150	150	150	150	150		TAPPI 569 om-22
Edge Wicking	kg/m ²	max. 1.0	0.5	0.5	0.5	0.5	0.5	0.5	0.5	0.5		Mill method
Cobb ₆₀ , Top	g/m ²	max. 60	30	30	30	30	30	30	30	30		ISO 535
Cobb ₆₀ , Reverse	g/m ²	max. 60	30	30	30	30	30	30	30	30		ISO 535
Moisture	%	±1	7.4	7.8	8.2	8.2	8.2	8.2	8.6	8.6		ISO 287
Robinson chocolate test	-		< 1 for one year storage in reels/pallets									EN1230-2

Edge wicking test: For hardsized.

All properties according to mill measurements from board machine production. Laboratory test climate 23°C/50% RH (according to ISO 187). Tolerances based upon 95% confidence limits, apply to delivered reel/pallet average.

Bending moment Taber 15° calculated from Bending resistance L&W 15°.

Performa Nova™

Fully coated CTMP board with uncoated reverse, FiberLight Tec™

Certificates

Quality management ISO 9001
 Environmental management ISO 14001
 Food safety FSSC 22000
 Occupational health and safety ISO 45001
 Energy management ISO 50001



FSC and PEFC certified board available upon request.



Paperboard can be recycled

Key characteristics and main enduses

Performa Nova is produced with patented FiberLight Tec™, a technology that creates exceptionally light and strong board, Performa Nova is designed to be superiorly efficient.

The key characteristics of Performa Nova include high bulk and stiffness, excellent smoothness and great visual appearance. Performa Nova is a world-class choice for a wide range of applications. The superior quality of Performa Nova makes it attractive for strong brands. Tailor-made for a range of food packaging applications with food safety compliance and odour&taste guarantee. At the same time, the light weight and strength characteristics ensure high material efficiency throughout the value chain.

Printing and finishing techniques

The product can be used with different printing techniques such as offset, flexo and digital printing. In digital printing, the product is suitable for several different sheet- or web-fed presses. Inkjet, dry or liquid toner technology can be used, although in some cases, pretreatment of the substrate might be required. The latest certification status can be verified on the press manufacturer's website or with local Stora Enso representatives. It is important to check the limitations of the equipment, particularly because of the exceptional difference in the thickness and stiffness of board compared with paper in the same grammages. When running thicker substrates, the press manufacturer's recommendations should be referred to for optimal grain direction. Essentially all the same finishing processes apply to both digitally printed and offset printed work. Since a wide variety of digital printing equipment is available in the market, it is important that a new commercial print job is always preceded by a trial run, including all required printing and converting process phases. The product works very well with different finishing techniques, such as embossing, hot foil stamping and others. It is suitable for laser coding and ink jet marking. Certificates according to PTS-DF 105/2023 and PTS-DF 103/2022 are available upon request.

Storage recommendations

For optimal printing results, the moisture proof wrapping should not be removed until the board has reached the temperature of the press room.

Pallet/Reel Weight (kg)	Difference in temperature between board and press room (press room temp. approx. 20°C)		
	10°C	20°C	30°C
400 kg	2 days	2 days	3 days
800 kg	2 days	3 days	4 days
1200 kg	2 days	4 days	5 days

The product properties, according to the specifications, are guaranteed for 12 months after the production date. In order to ensure product safety, the product must be well wrapped and stored in its original cover indoors, sheltered from rain and snow. The recommended storage conditions are 50–55% relative humidity and 20–23°C.