

# Performa Natura™

## Fully coated CTMP board with uncoated reverse

Performa Natura is a board with a three layer fibre construction and with CTMP (chemi-thermomechanical pulp) in the middle layer and a double-pigment-coated top side.

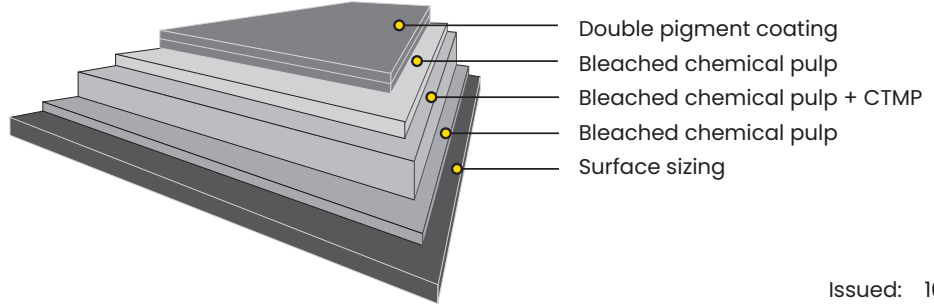

Issued: 10.2025  
Replaces: 02.2024

### Technical specification

Typical properties, Imperial		Unit									
Caliper	pts		10.2	11.0	12.6	13.8	15.4	16.9	18.5	20.1	
Nominal basis weight	g/m <sup>2</sup>		39.9	43.0	47.1	52.2	55.3	60.4	65.5	71.7	
Bending moment Taber 15° MD	mNm		59	76	106	133	177	234	296	374	
Bending moment Taber 15° CD	mNm		28	35	47	61	84	103	133	167	
Scott Bond	J/m <sup>2</sup>		95	95	95	95	95	95	95	95	
Typical properties, Metric		Tolerance									Method
Thickness	µm	±4%	260	280	320	350	390	430	470	510	ISO 534
Grammage	g/m <sup>2</sup>	±4%	195	210	230	255	270	295	320	350	ISO 536
Bending resistance L&W 15° MD	mN	-15%	120	155	215	270	360	475	600	760	ISO 2493
Bending resistance L&W 15° CD	mN	-15%	55	70	95	125	170	210	270	340	ISO 2493
Bending moment Taber 15° MD	mNm	-15%	5.8	7.5	10.4	13.0	17.4	22.9	29.0	36.7	
Bending moment Taber 15° CD	mNm	-15%	2.7	3.4	4.6	6.0	8.2	10.1	13.0	16.4	
Bending stiffness DIN 5° MD	mNm	-15%	10.2	13.2	18.3	23.0	30.6	40.4	51.0	64.6	
Bending stiffness DIN 5° CD	mNm	-15%	4.7	6.0	8.1	10.6	14.5	17.9	23.0	28.9	
Moisture	%		6.5	6.5	6.5	6.5	6.5	6.5	6.5	6.5	ISO 287
ISO Brightness C/2°, Top	%		85	85	85	85	85	85	85	85	ISO 2470-1
ISO Brightness D65/10°, Top	%		85	85	85	85	85	85	85	85	ISO 2470-2
Surface Smoothness PPS10, Top	µm		1.2	1.2	1.2	1.2	1.2	1.2	1.2	1.2	ISO 8791-4
Gloss 75°	%		45	45	45	45	45	45	45	45	ISO 8254-1
Scott Bond	J/m <sup>2</sup>		200	200	200	200	200	200	200	200	TAPPI 569 om-22
Robinson chocolate test	-		max 0.5 for one year storage in reels/pallets							EN1230-2	

OBA non-added

All properties according to mill measurements from board machine production. Laboratory test climate 23°C/50% RH (According to ISO 187). Tolerances based upon 95% confidence limits, apply to delivered reel/pallet average.

Bending moment Taber 15° and Bending resistance L&W 15° are binding. Bending stiffness DIN 5° are indicative. Bending moment Taber 15° calculated from Bending resistance L&W 15°.

# Performa Natura™

Fully coated CTMP board with uncoated reverse

## Certificates

Quality management ISO 9001  
 Environmental management ISO 14001  
 Food safety FSSC 22000  
 Occupational health and safety ISO 45001  
 Energy management ISO 50001



FSC and PEFC certified board available upon request.



Paperboard can be recycled

## Key characteristics and main enduses

Performa Natura features a technically advanced structure for material efficiency, toughness, bulk and runnability. No optical brightening additives are used in production of Performa Natura. As a OBA non-added board Performa Natura is highly suitable for pharmaceuticals, food and chocolate packaging. This product is compostable in industrial and home composting and can be collected together with food waste in most collecting schemes.

## Printing and finishing techniques

The product can be used with different printing techniques such as offset, flexo and digital printing. In digital printing, the product is suitable for several different sheet- or web-fed presses. Dry or liquid toner technology can be used, although in some cases, pretreatment of the substrate might be required. The latest certification status can be verified on the press manufacturer's website or with local Stora Enso representatives. It is important to check the limitations of the equipment, particularly because of the exceptional difference in the thickness and stiffness of board compared with paper in the same grammages. When running thicker substrates, the press manufacturer's recommendations should be referred to for optimal grain direction. Essentially all of the same finishing processes apply to both digitally printed and offset printed work. Since a wide variety of digital printing equipment is available in the market, it is important that a new commercial print job is always preceded by a trial run, including all required printing and converting process phases. It is suitable for laser coding. Certificate according to PTS-DF 105/2023 is available upon request.

## Storage recommendations

For optimal printing results, the moisture proof wrapping should not be removed until the board has reached the temperature of the press room.

Pallet/Reel Weight (lbs)	Difference in temperature between board and press room		
	50°F	68°F	86°F
881 lbs (400 kg)	2 days	2 days	3 days
1762 lbs (800 kg)	2 days	3 days	4 days
2643 lbs (1200 kg)	2 days	4 days	5 days

The product properties, according to the specifications, are guaranteed for 12 months after the production date. In order to ensure product safety, the product must be well wrapped and stored in its original cover indoors, sheltered from rain and snow. The recommended storage conditions are 50–55% relative humidity and 68–73.4°F.