

Cupforma Dairy™ 2PE Green

SBS dairy board with renewable coating

Cupforma Dairy 2PE Green is an uncoated virgin-fibre SBS board with a three layer fibre construction and LDPE Green coating on both sides.

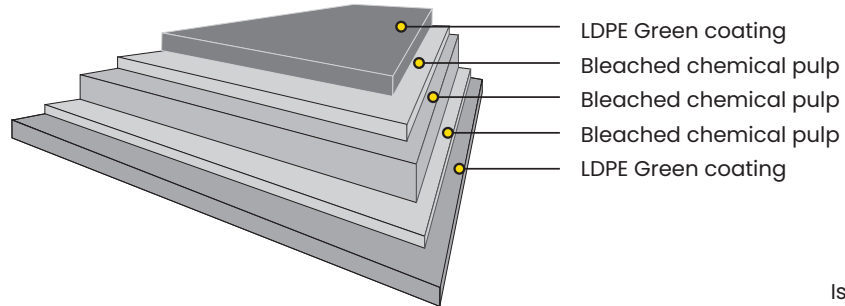

Issued: 09.2025
Replaces: 05.2024

Technical specification

Property	Unit	Tolerance	20+210+35	20+230+35	20+248+35	20+283+35	20+310+35	Standard
Barrier coated board:								
Grammage	g/m ²	± 5%	265	285	303	338	365	ISO 536
Bio-based LDPE coating	g/m ²	± 2	20	20	20	20	20	Mill method
Bio-based LDPE coating	g/m ²	± 2	35	35	35	35	35	Mill method
Thickness	µm	± 6 %	325	350	380	430	460	ISO 534
Corona treating	mN/m	min 39	42	42	42	42	42	ASTM D 2578
Baseboard:								
Grammage	g/m ²	± 4%	210	230	248	283	310	ISO 536
Thickness	µm	± 6%	275	300	330	380	410	ISO 534
Bending resistance L&W 15° MD	mN	min -25%	145	200	255	380	500	ISO 2493
Bending resistance L&W 15° CD	mN	min -25%	55	75	95	150	195	ISO 2493
Moisture	%	min 6.4%	7.5	7.5	7.5	7.5	7.5	ISO 287
ISO Brightness D65/10°	%	min 80	85	85	85	85	85	ISO 2470-2
Surface Smoothness Bendtsen	ml/min	max 400	300	300	300	350	350	ISO 8791-2
Tensile stretch CD	%	min 4.5%	6.0	6.0	6.0	6.0	6.0	ISO 1924-3

OBA free

Corona treating is measured right after PE coating.

Cupforma Dairy™ 2PE Green

SBS dairy board with renewable coating

Certificates

Quality management ISO 9001
 Environmental management ISO 14001
 Food safety FSSC 22000
 Occupational health and safety ISO 45001
 Energy management ISO 50001



FSC and PEFC certified board available upon request.



Paperboard can be recycled

Key characteristics and main enduses

Cupforma Dairy 2PE Green is specially designed for cups for dairy products, which have high requirements for the board and exceptionally high standard for odour and taint neutrality. It is food-safe and the baseboard and coating are based on renewable materials. Cupforma Dairy 2PE Green works smoothly and consistently in cup the converting. It delivers excellent results in flexographic, offset, and digital printing to showcase brands. It is sealed easily into a cup, and used for dairy products like yogurt.

Printing and finishing techniques

The product can be used for different printing techniques such as offset, flexo and digital printing. It is important to check possible limitations of the printing and converting equipment and ensure that the basis weight of the board fits the tooling to be used. Since a wide variety of digital printing equipment is available in the market, it is important that a new commercial digital print job is always preceded by a trial run, including all required printing and converting process phases.

Storage recommendations

For optimal printing results, the moisture proof wrapping should not be removed until the board has reached the temperature of the press room.

Pallet/Reel Weight (kg)	Difference in temperature between board and press room (press room temp. approx. 20°C)		
	10°C	20°C	30°C
400 kg	2 days	2 days	3 days
800 kg	2 days	3 days	4 days
1200 kg	2 days	4 days	5 days

The product properties, according to the specifications, are guaranteed for 12 months after the production date. In order to ensure product safety, the product must be well wrapped and stored in its original cover indoors, sheltered from rain and snow. The recommended storage conditions are 50–55% relative humidity and 20–23°C.

For the Corona treatment, we recommend using the board within 12 months of the production date; after this period, the treatment level should be tested before printing or gluing.